

## ISO SHANK COLLET HOLDER FOR 'RDO' (OZ) COLLETS

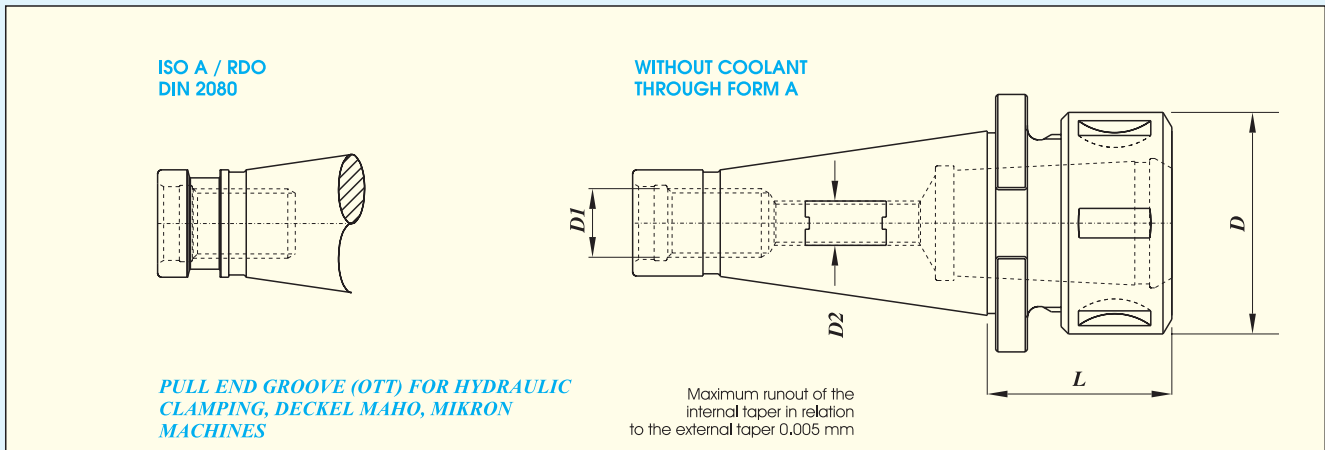

Collet Chuck Designation	Suitable for Collet	Collet Clamping Capacity	L	D1	D2	Nut		Spanner Designation
						D	Designation	
ISO 40 A RDO 25050	RDO 25 (OZ16)	1.5 - 16	50	M 16	M 10 X 1	43	KM/RDO 25	HS 25
ISO 40 A RDO 35060	RDO 35 (OZ 25)	1.5 - 25	60	M 16	M 12 X 1	60	KM/RDO 35	HS 35
ISO 50 A RDO 35065	RDO 35 (OZ 25)	1.5 - 25	65	M 24	M 12 X 1	60	KM/RDO 35	HS 35
ISO 50 A RDO 44070	RDO 44 (OZ 32)	3.5 - 32	70	M 24	M 18 X 1	72	KM/RDO 44	HS 44

Ordering Example :-  
 KTA ISO 40 A RDO 25050 Without coolant / Qty.- 2 Nos. For Ball Bearing Nut (KM/ER) refer page no. 24  
 KTA ISO 40 A RDO 25050 Deckel Mikron Maho (OTT), Without coolant / Qty.- 2 Nos.

## ISO SHANK COLLET HOLDER FOR 'RDO' (OZ) COLLETS

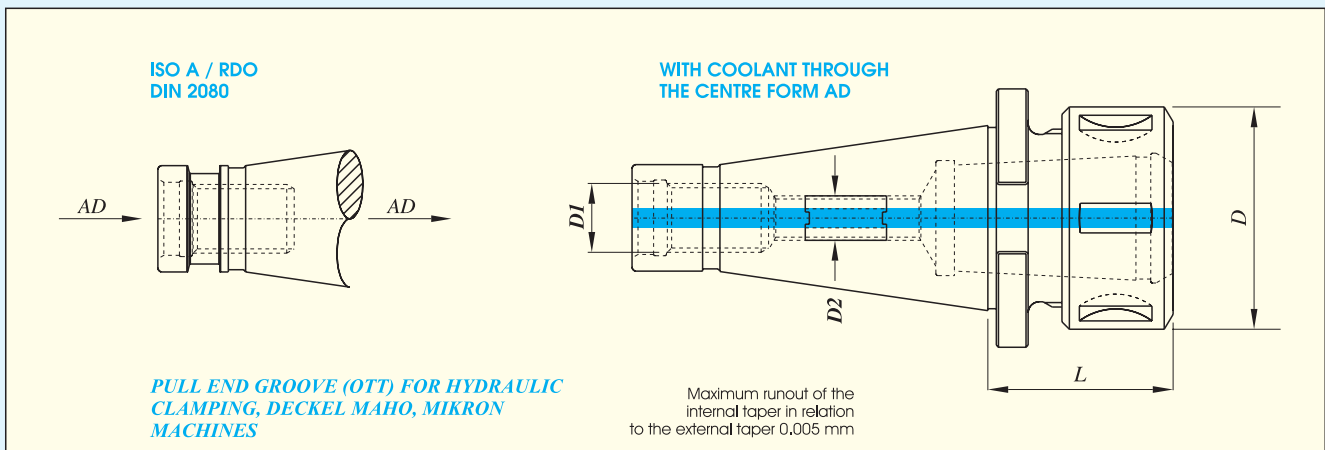

Collet Chuck Designation	Suitable for Collet	Collet Clamping Capacity	L	D1	D2	Nut		Spanner Designation
						D	Designation	
ISO 40 AD RDO 25050	RDO 25 (OZ16)	1.5 - 16	50	M 16	M 10 X 1	43	KM/RDO 25	HS 25
ISO 40 AD RDO 35060	RDO 35 (OZ 25)	1.5 - 25	60	M 16	M 12 X 1	60	KM/RDO 35	HS 35
ISO 50 AD RDO 35065	RDO 35 (OZ 25)	1.5 - 25	65	M 24	M 12 X 1	60	KM/RDO 35	HS 35
ISO 50 AD RDO 44070	RDO 44 (OZ 32)	3.5 - 32	70	M 24	M 18 X 1	72	KM/RDO 44	HS 44

Ordering Example :-  
 KTA ISO 40 AD RDO 25050 With coolant through Center /Qty.- 2 Nos. For Ball Bearing Nut (KM/ER) refer page no. 24  
 KTA ISO 40 AD RDO 25050 Deckel Mikron Maho (OTT), With coolant through Center /Qty.- 2 Nos.